

2 WAY DIRECT ACTING SOLENOID VALVE NORMALLY CLOSED FOR VENDING MACHINES



FLOCON® 2 way direct acting specialised food grade dry armature dispense solenoid valve is widely accepted by the vending industry in India. Valves are supplied with flow control & vent.

TECHNICAL SPECIFICATION

- | | |
|----------------------------|--|
| 1) Construction | - Dry Armature for Hygiene and Reliability |
| 2) Operating Pressure | - 0 to 0.5 kg/cm ² |
| 3) Operating Temperature | - 0° to 95°C |
| 4) Material | - All food grade material in contact with media. |
| 5) Seat | - Valve seat operates with wiping action to avoid limescale. |
| 6) Port Size | - 8 mm |
| 7) Medium | - Hot Water |
| 8) Coil Voltage | - 230V AC/24V DC ± 10% |
| 9) Body material | - Acetal / Polycarbonate |
| 10) Armature tube Assembly | - Brass |
| 11) Coil | - Epoxy moulded IP -65, 'F' Class for (155°C)
Coil watts - 8, Current - 60 mA |

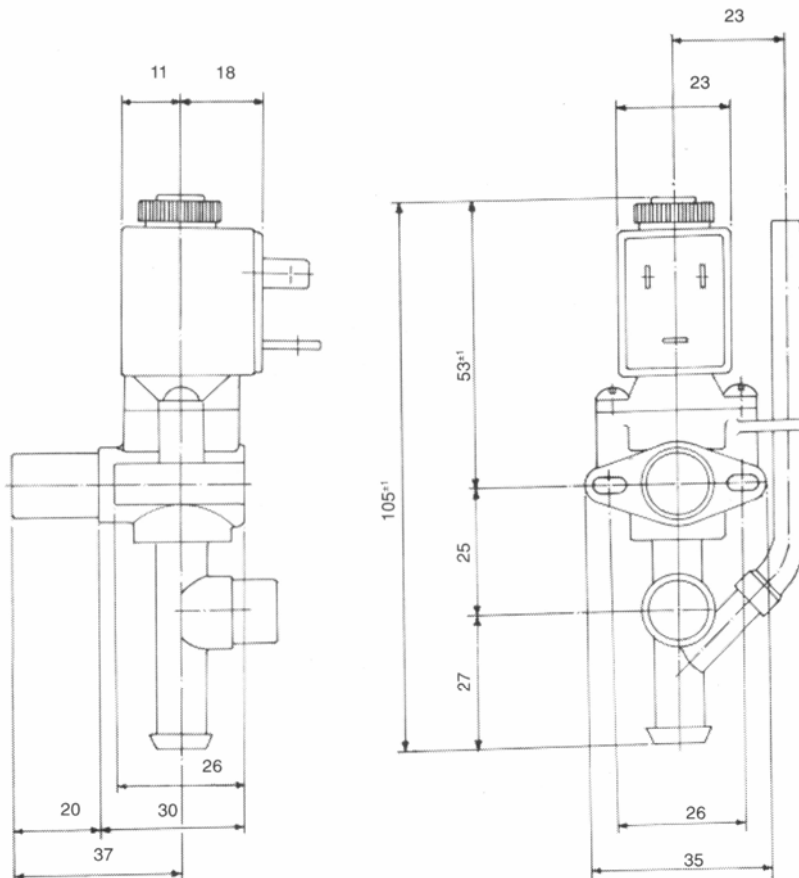

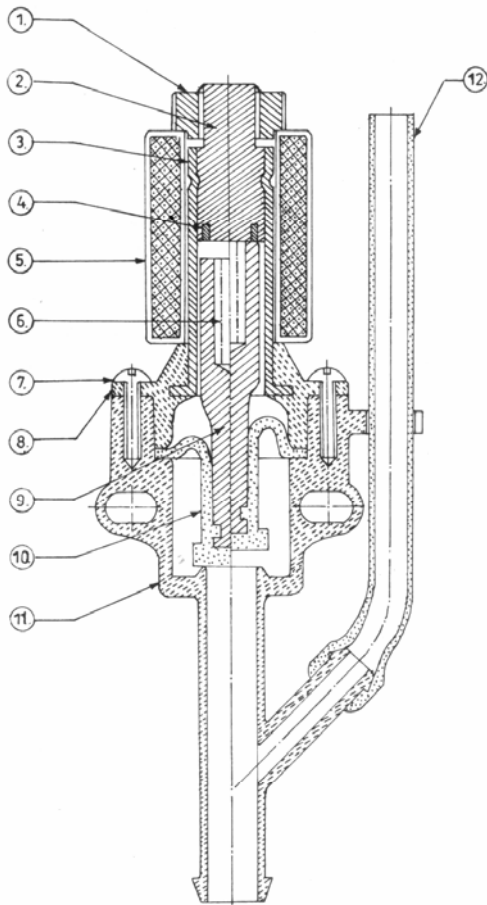

PART LIST

SR. NO.	NAME OF THE PART	MATERIAL	PART NO.	QTY.
1.	TOP NUT	SS-304	FDV - 2001	1.
2.	STOPPER	SS-430	FDV - 2002	1.
3.	ARMATURE TUBE ASSLY.	BRASS	FDV - 2003	1.
4.	SHADING COIL	COPPER	FDV - 2004	1.
5.	SOLENOID	ENML. CU WIRE	FDV - 2005	1.
6.	PLUNGER SPRING	SS-304	FDV - 2006	1.
7.	ASSEMBLY SCREW	SS-304	FDV - 2007	2.
8.	BONNET	ACETAL/ POLYCARBONATE	FDV - 2008	1.
9.	PLUNGER	SS-430	FDV - 2009	1.
10.	DIAPHRAGM	SILICONE	FDV - 2010	1.
11.	VALVE BODY	ACETAL/ POLYCARBONATE	FDV - 2011	1.
12.	VENT	SILICONE	FDV - 2012	1.

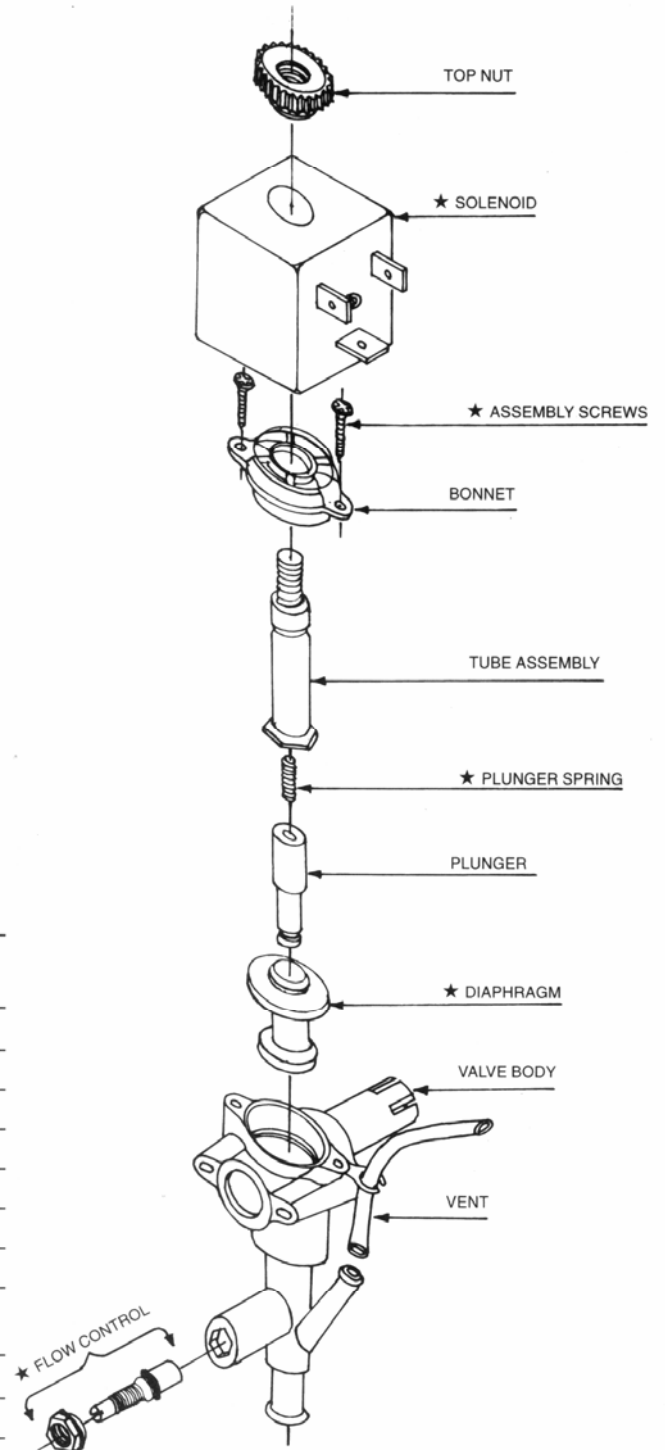

★ RECOMMENDED SPARES / PARTS

PRECISION
INSTRUMENT
CO.

Office & Works :

124- A-Z Industrial Estate, G. K. Marg, Mumbai - 400 013

Tel. : 2492 6384, 2492 4333 • Fax : 2497 4299

E-mail : flocon@bom3.vsnl.net.in

Website : www.floconvalves.com